

## SECTION 9D

# WIPERS/WASHER SYSTEMS

**CAUTION:** Disconnect the negative battery cable before removing or installing any electrical unit or when a tool or equipment could easily come in contact with exposed electrical terminals. Disconnecting this cable will help prevent personal injury and damage to the vehicle. The ignition must also be in LOCK unless otherwise noted.

## TABLE OF CONTENTS

<b>Specifications</b> .....	<b>9D-1</b>	Windshield Wiper Blade .....	9D-10
Fastener Tightening Specifications .....	9D-1	Windshield Wiper Blade Insert .....	9D-11
<b>Schematic and Routing Diagrams</b> .....	<b>9D-2</b>	Windshield Washer Reservoir .....	9D-12
Windshield Wipers and Washer System .....	9D-2	Windshield Washer Pump .....	9D-13
<b>Diagnosis</b> .....	<b>9D-3</b>	Windshield Washer Nozzles .....	9D-14
Two-Speed Intermittent Windshield Wipers ...	9D-3	Windshield Washer Hoses .....	9D-14
Windshield Washer System .....	9D-7	<b>General Description and System</b>	
<b>Maintenance and Repair</b> .....	<b>9D-8</b>	<b>Operation</b> .....	<b>9D-16</b>
On-Vehicle Service .....	9D-8	Windshield Wiper System .....	9D-16
Windshield Wiper Arm .....	9D-8	Windshield Washer System .....	9D-16
Windshield Wiper Motor .....	9D-8		

## SPECIFICATIONS

### FASTENER TIGHTENING SPECIFICATIONS

Application	N•m	Lb-Ft	Lb-In
Cowl Vent Grille Screw	2.5	–	22
Washer Fluid Reservoir Bolts	9	–	80
Wiper Arm Linkage Nut	16	12	–
Wiper Arm Nut	7	–	62
Wiper Motor Bolts	4	–	36

# SCHEMATIC AND ROUTING DIAGRAMS

## WINDSHIELD WIPERS AND WASHER SYSTEM

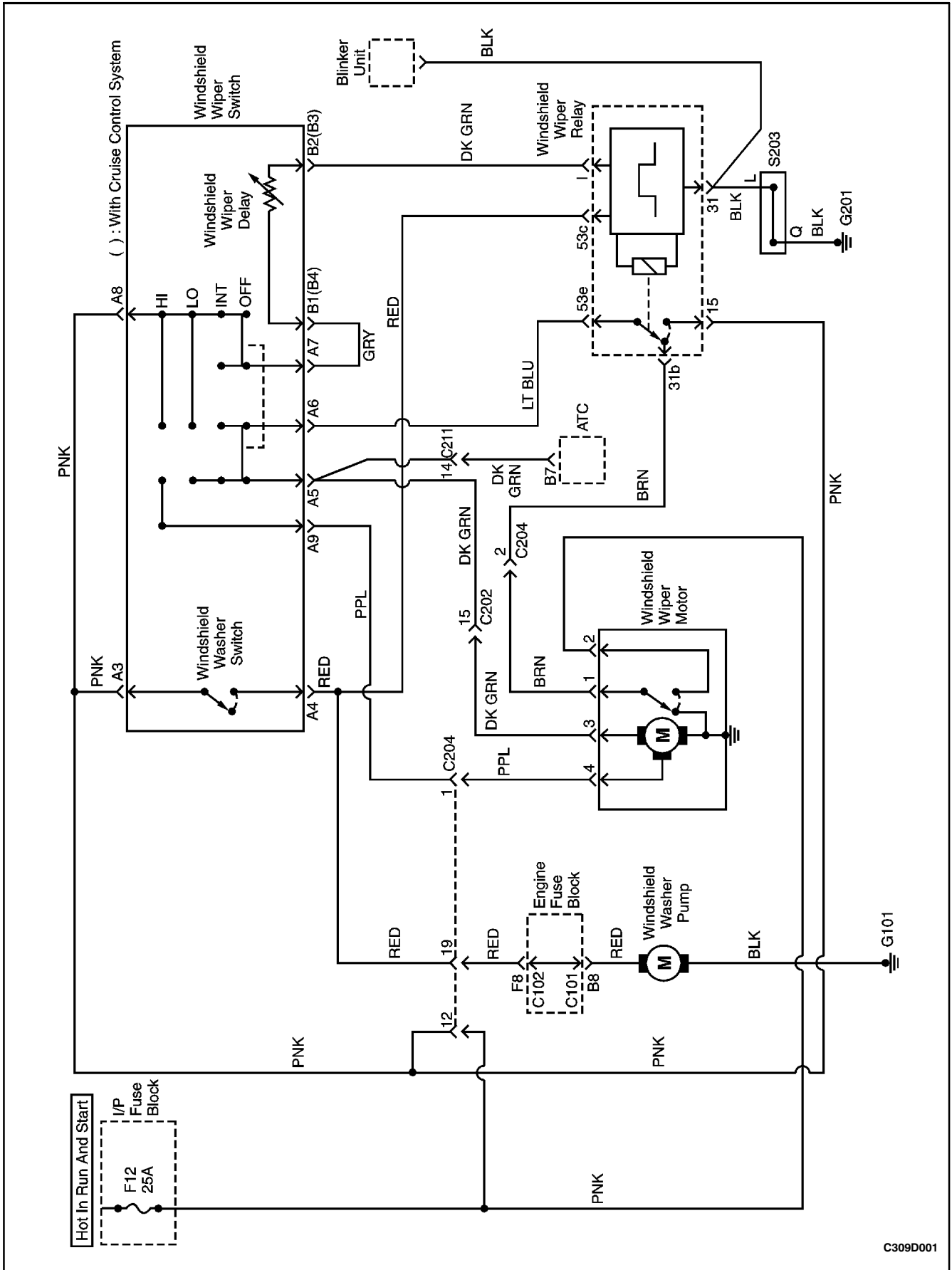

C309D001

## DIAGNOSIS

**TWO-SPEED INTERMITTENT WINDSHIELD WIPERS****Windshield Wipers Do Not Work At Any Speed**

<b>Step</b>	<b>Action</b>	<b>Value</b>	<b>Yes</b>	<b>No</b>
1	Check fuse F12. Is fuse F12 blown?	-	Go to <i>Step 2</i>	Go to <i>Step 3</i>
2	1. Check for a short circuit and repair if necessary. 2. Replace the fuse. Is the repair complete?	-	System OK	-
3	Check the voltage at fuse F12. Is the voltage equal to the specified value?	11-14 V	Go to <i>Step 5</i>	Go to <i>Step 4</i>
4	Repair the open power supply circuit to fuse F12. Is the repair complete?	-	System OK	-
5	1. Disconnect the wiper motor connector. 2. Turn the ignition ON. 3. Turn the wiper switch to HI. 4. Check the voltage at the wiper motor connector terminal 4. Is the voltage equal to the specified value?	11-14 V	Go to <i>Step 6</i>	Go to <i>Step 7</i>
6	Replace the wiper motor. Is the repair complete?	-	System OK	-
7	1. The wiper switch is still disconnected. 2. Turn the ignition ON. 3. Check for battery voltage at the wiper switch connector terminal A8. Is the voltage equal to the specified value?	11-14 V	Go to <i>Step 9</i>	Go to <i>Step 8</i>
8	Repair the open circuit between the wiper switch connector terminal A8 and fuse F12. Is the repair complete?	-	System OK	-
9	1. The wiper switch is still disconnected. 2. Turn the wiper switch to HI. 3. Use an ohmmeter to check for continuity between the wiper switch connector terminal A8 and A9. Does the ohmmeter indicate the specified value?	0 Ω	Go to <i>Step 11</i>	Go to <i>Step 10</i>
10	Replace the wiper switch. Is the repair complete?	-	System OK	-
11	Repair the open circuit between the wiper switch and the wiper motor. Is the repair complete?	-	System OK	-

**Windshield Wipers Do Not Work On HI Speed, LO Speed OK**

Step	Action	Value	Yes	No
1	1. Turn the ignition ON. 2. Turn the wiper switch to HI. 3. Check voltage at the wiper motor connector terminal 4. Is the voltage equal to the specified value?	11-14 V	Go to <i>Step 2</i>	Go to <i>Step 3</i>
2	Replace the wiper motor. Is the repair complete?	-	System OK	-
3	1. Disconnect the wiper switch. 2. Turn the wiper switch to HI. 3. Use an ohmmeter to check for continuity between the wiper switch connector terminal A8 and A9. Does the ohmmeter indicate the specified value?	0 Ω	Go to <i>Step 5</i>	Go to <i>Step 4</i>
4	Replace the wiper switch. Is the repair complete?	-	System OK	-
5	Repair the open circuit between the wiper switch connector terminal A9 and the wiper motor connector terminal 4. Is the repair complete?	-	System OK	-

**Windshield Wipers Do Not Work On LO Speed, HI Speed OK**

Step	Action	Value	Yes	No
1	1. Turn the ignition ON. 2. Turn the wiper switch to LO. 3. Check the voltage at the wiper motor connector terminal 3. Is the voltage equal to the specified value?	11-14 V	Go to <i>Step 2</i>	Go to <i>Step 3</i>
2	Replace the wiper motor. Is the repair complete?	-	System OK	-
3	1. Disconnect the wiper switch. 2. Turn the wiper switch to LO. 3. Use an ohmmeter to check for continuity between the wiper switch connector terminal A8 and A5. Does the ohmmeter indicate the specified value?	0 Ω	Go to <i>Step 5</i>	Go to <i>Step 4</i>
4	Replace the wiper switch. Is the repair complete?	-	System OK	-
5	Repair the open circuit between the wiper switch connector terminal A5 and the wiper motor connector terminal 3. Is the repair complete?	-	System OK	-

## Windshield Wipers Do Not Work On Intermittent, Other Speeds OK

Step	Action	Value	Yes	No
1	1. Turn the ignition ON. 2. Use a voltmeter to test voltage at the wiper relay connector terminal 15. Is voltage equal to the specified value?	11-14 V	Go to Step 3	Go to Step 2
2	Repair the open circuit between the wiper relay connector terminal 15 and fuse F12. Is the repair complete?	-	System OK	-
3	1. Turn the ignition ON. 2. Turn the wiper switch to INT. 3. Check the voltage at the wiper relay connector terminal I. Does the voltmeter indicate a voltage equal to the specified value?	11-14 V	Go to Step 7	Go to Step 4
4	Check for an open circuit between wiper switch connector terminal B2 (B3, if equipped cruise control system) and wiper relay connector terminal I. Is there an open circuit?	-	Go to Step 6	Go to Step 5
5	Replace the wiper switch. Is the repair complete?	-	System OK	-
6	Repair the open circuit between wiper switch connector terminal B2 (B3, if equipped cruise control system) and wiper relay connector terminal I. Is the repair complete?	-	System OK	-
7	1. Turn the ignition ON. 2. Turn the wiper switch to INT. 3. Check the voltage pulsing at the wiper relay connector terminal 53e. Does the voltmeter indicate a pulsating voltage equal to the specified value?	11-14 V	Go to Step 11	Go to Step 8
8	Using an ohmmeter, check the resistance between ground and the wiper relay connector terminal 31. Is resistance equal to the specified value?	0 $\Omega$	Go to Step 10	Go to Step 9
9	Repair the open ground circuit. Is the repair complete?	-	System OK	-
10	Replace the wiper relay. Is the repair complete?	-	System OK	-
11	1. Turn the ignition ON. 2. Check the voltage at the wiper switch connector terminal A6. Is the voltage pulsating at the specified value?	-	Go to Step 12	Go to Step 13
12	Replace the wiper switch. Is the repair complete?	-	System OK	-
13	Repair the open circuit between the wiper switch and the wiper relay. Is the repair complete?	-	System OK	-

## Windshield Wipers Do Not Return To Park Position

Step	Action	Value	Yes	No
1	1. Turn the ignition ON. 2. Check the voltage at the wiper motor connector terminal 2. Is the voltage equal to the specified value?	11-14 V	Go to <i>Step 3</i>	Go to <i>Step 2</i>
2	Repair the open circuit between the wiper motor and fuse F12. Is the repair complete?	-	System OK	-
3	1. Turn the wiper switch to HI. 2. While turning the wiper switch OFF, check the voltage at the wiper motor connector terminal 3. Is the specified voltage indicated when the wiper switch is turned OFF?	11-14 V	Go to <i>Step 5</i>	Go to <i>Step 4</i>
4	Replace the wiper motor. Is the repair complete?	-	System OK	-
5	1. Disconnect the wiper relay. 2. Check continuity between the wiper relay terminal 31b and 53e. Does the ohmmeter indicate the specified value?	0 Ω	Go to <i>Step 6</i>	Go to <i>Step 7</i>
6	Repair the open circuit between the wiper motor and the wiper relay. Is the repair complete?	-	System OK	-
7	Replace the wiper relay. Is the repair complete?	-	System OK	-

**WINDSHIELD WASHER SYSTEM****Windshield Washer Inoperative, Wipers Work OK**

<b>Step</b>	<b>Action</b>	<b>Value</b>	<b>Yes</b>	<b>No</b>
1	Activate the windshield washer switch. Do the windshield wipers operate when the washer switch is activated?	-	Go to <i>Step 4</i>	Go to <i>Step 2</i>
2	1. Turn the ignition ON. 2. While activating the washer switch, test the voltage at the windshield wiper switch connector terminal A4. Is the voltage equal to the specified value?	11-14 V	Go to <i>Step 8</i>	Go to <i>Step 3</i>
3	Replace the wiper switch. Is the repair complete?	-	System OK	-
4	Check the windshield washer fluid reservoir. Is there washer fluid in the fluid reservoir?	-	Go to <i>Step 6</i>	Go to <i>Step 5</i>
5	Fill the windshield washer fluid reservoir. Is the repair complete?	-	System OK	-
6	Check the windshield washer hoses and the nozzles. Are the windshield washer hoses and the nozzles clogged or damaged?	-	Go to <i>Step 7</i>	Go to <i>Step 8</i>
7	Repair the washer hoses and the nozzles. Is the repair complete?	-	System OK	-
8	1. Turn the ignition ON. 2. With the windshield washer activated, test the voltage at the windshield washer pump. Is the voltage equal to the specified value?	11-14 V	Go to <i>Step 10</i>	Go to <i>Step 9</i>
9	Repair an open circuit between the windshield washer pump and the windshield wiper switch. Is the repair complete?	-	System OK	-
10	Use an ohmmeter to measure the resistance between ground and the windshield washer pump. Is the resistance equal to the specified value?	0 $\Omega$	Go to <i>Step 12</i>	Go to <i>Step 11</i>
11	Repair the windshield washer pump ground circuit. Is the repair complete?	-	System OK	-
12	Replace the windshield washer pump. Is the repair complete?	-	System OK	-

## MAINTENANCE AND REPAIR

### ON-VEHICLE SERVICE

#### WINDSHIELD WIPER ARM

(Left-Hand Drive Shown, Right-Hand Drive Similar)

##### Removal Procedure

1. Open the hood.
2. Remove the nut from the wiper arm.
3. Pull the wiper arm off.

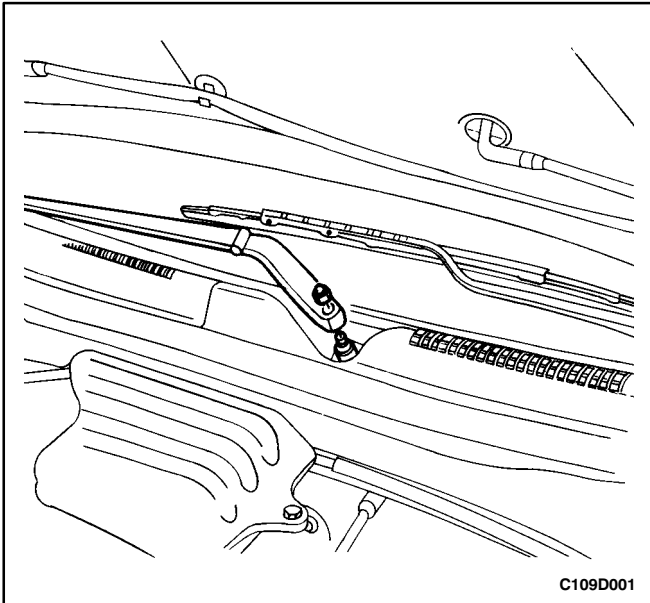

##### Installation Procedure

1. Install the wiper arm.

**Notice:** Dissimilar metals in direct contact with each other may corrode rapidly. Make sure to use the correct fasteners to prevent premature corrosion.

2. Secure the wiper arm with the nut.

##### Tighten

Tighten the wiper arm nut to 7 N•m (62 lb-in).

3. Close the hood.

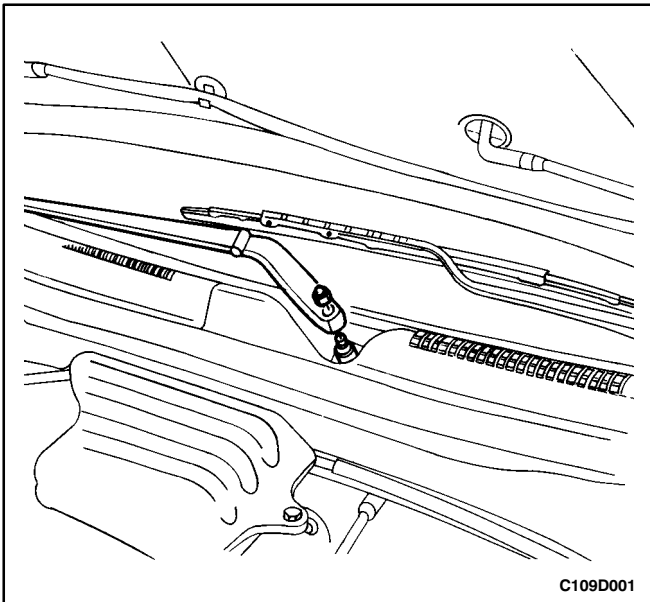

#### WINDSHIELD WIPER MOTOR

(Left-Hand Drive Shown, Right-Hand Drive Similar)

##### Removal Procedure

1. Disconnect the negative battery cable.
2. Remove the screws and the left side portion of the cowl vent grille.

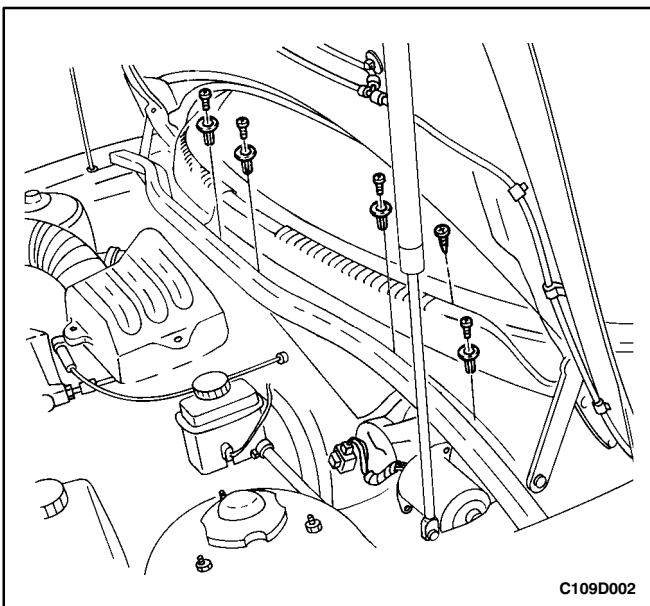



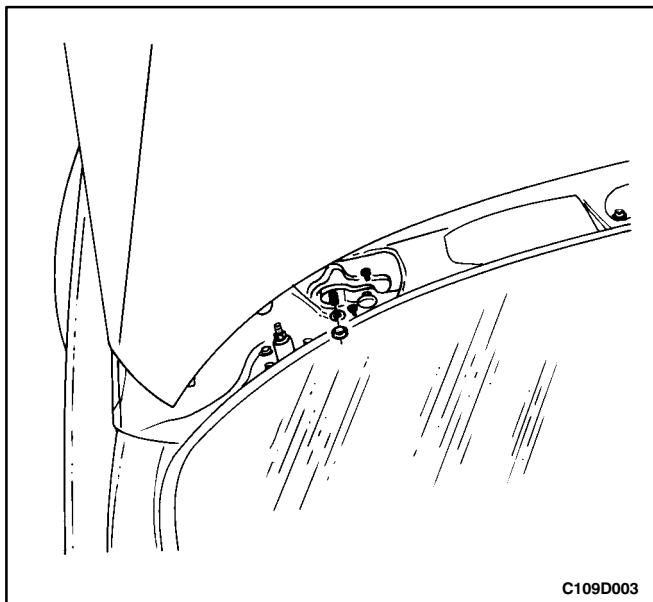

C109D003

3. Remove the nut and the washer securing the wiper arm linkage to the motor drive shaft.

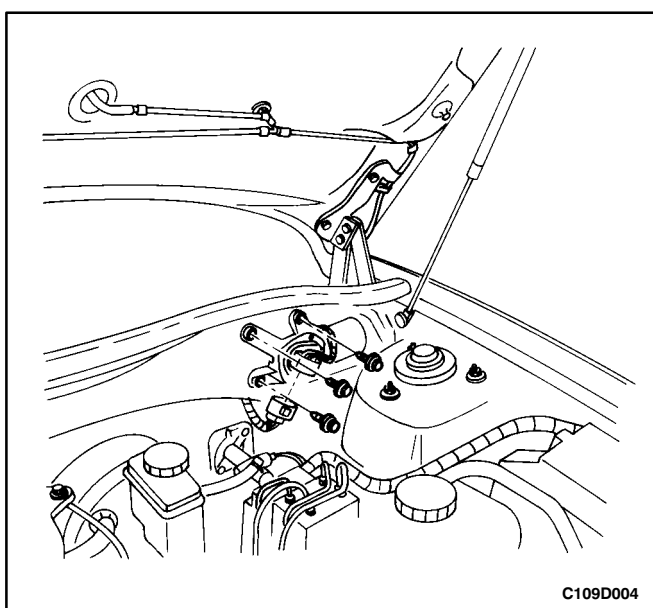

C109D004

4. Pry the wiper arm linkage off the motor drive shaft.
5. Disconnect the electrical connector.
6. Remove the bolts and the wiper motor.

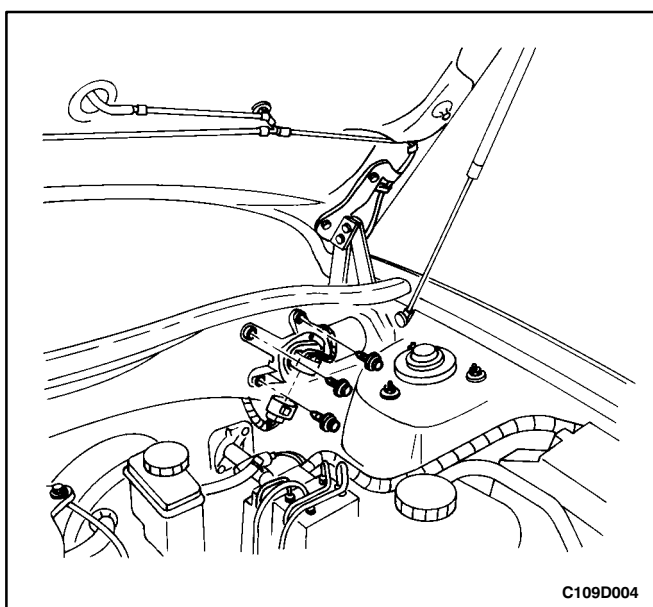

C109D004

### Installation Procedure

**Notice:** Dissimilar metals in direct contact with each other may corrode rapidly. Make sure to use the correct fasteners to prevent premature corrosion.

1. Install the wiper motor with the bolts.

#### Tighten

Tighten the wiper motor bolts to 4 N•m (36 lb-in).

2. Connect the electrical connector.

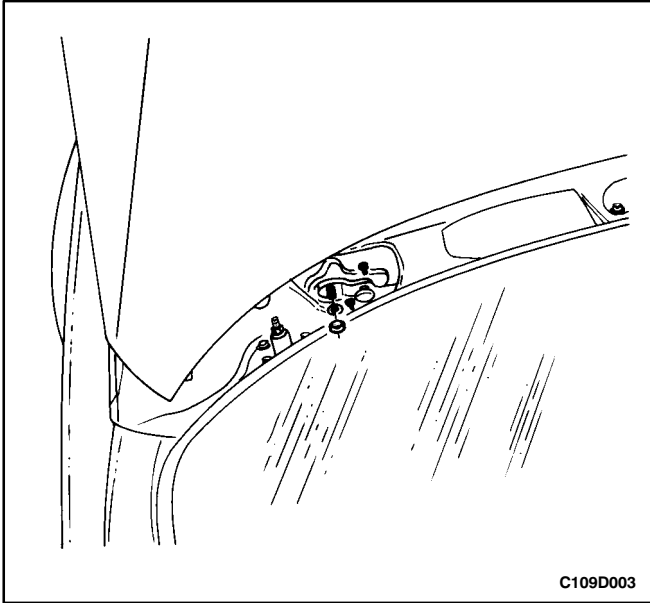

3. Press the wiper arm linkage onto the motor drive shaft.
4. Install the wiper arm linkage to the motor drive shaft with the washer and the nut.

### **Tighten**

Tighten the wiper arm linkage nut to 16 N•m (12 lb-ft).

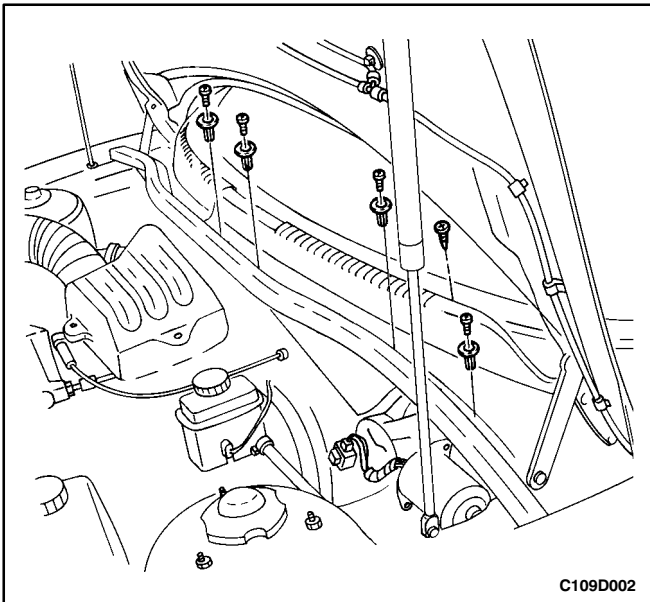

5. Install the left side portion of the cowl vent grille with the screws.

### **Tighten**

Tighten the cowl vent grille screw to 2.5N•m (22 lb-in).

6. Connect the negative battery cable.

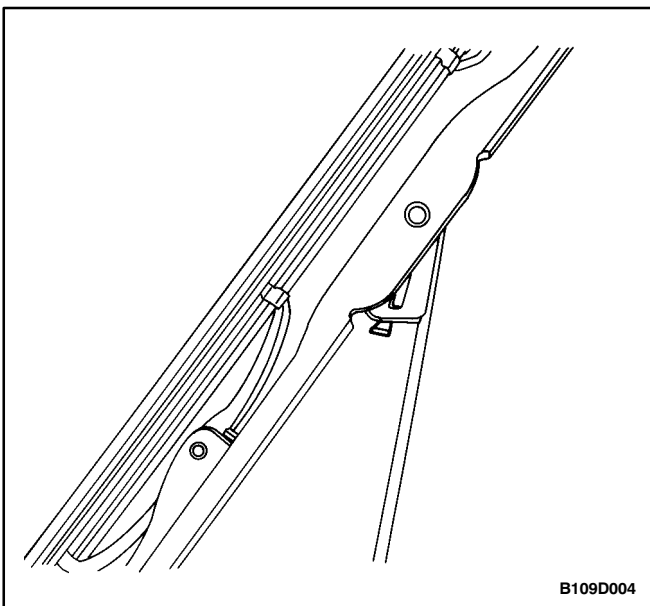

## **WINDSHIELD WIPER BLADE**

### **Removal Procedure**

1. Rotate the wiper blade on the arm.
2. While pressing the retainer clip, slide the wiper blade down the wiper arm and remove the blade.

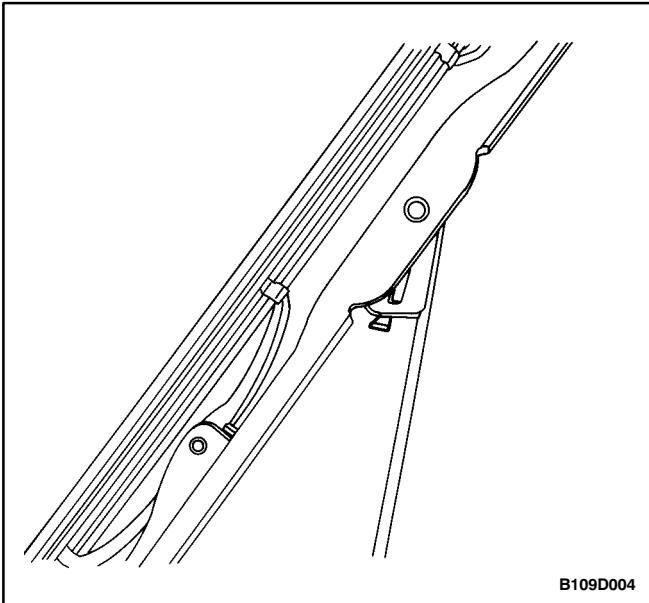

B109D004

**Installation Procedure**

1. Install the wiper blade by sliding it onto the arm until the retainer clip engages.

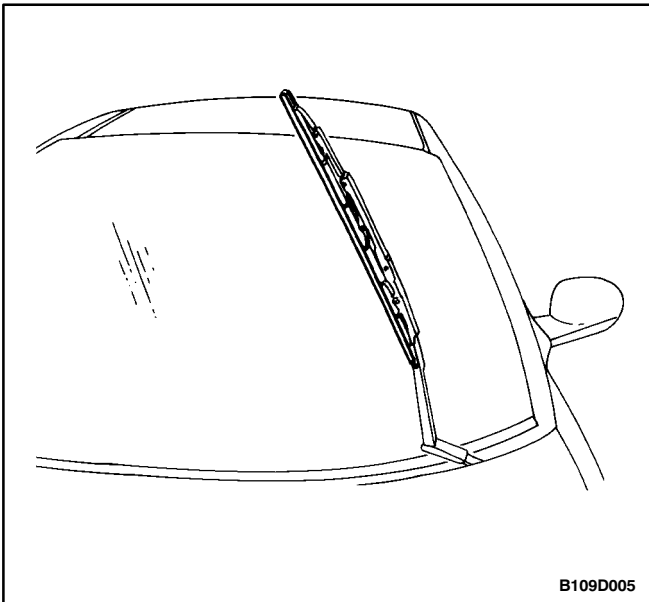

B109D005

**WINDSHIELD WIPER BLADE INSERT**

**Removal Procedure**

1. Slide the insert out of the wiper blade.

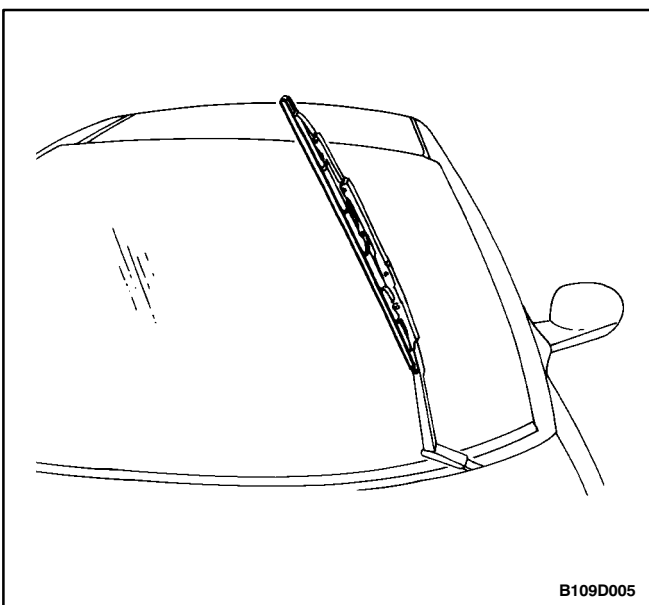

B109D005

**Installation Procedure**

1. Slide the insert into the wiper blade.

## WINDSHIELD WASHER RESERVOIR

### Removal Procedure

1. Disconnect the negative battery cable.
2. Remove the front left wheel. Refer to *Section 2E, Tires and Wheels*.
3. Remove the front wheel well splash shield. Refer to *Section 9R, Body Front End*.
4. Disconnect the washer hose from the washer pump.
5. Disconnect the reservoir pump electrical connector.

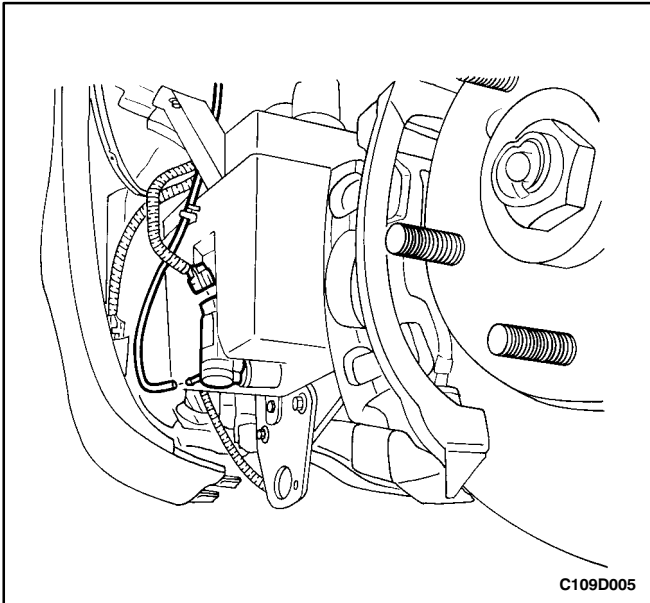

6. Remove the bolts and the reservoir.

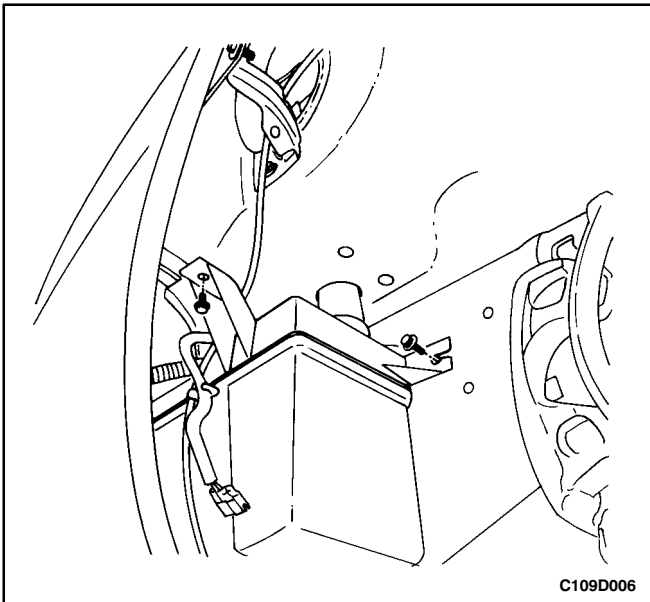

### Installation Procedure

**Notice:** Dissimilar metals in direct contact with each other may corrode rapidly. Make sure to use the correct fasteners to prevent premature corrosion.

1. Install the reservoir with the bolts.

#### Tighten

Tighten the washer fluid reservoir bolts to 9 N•m (80 lb-in).

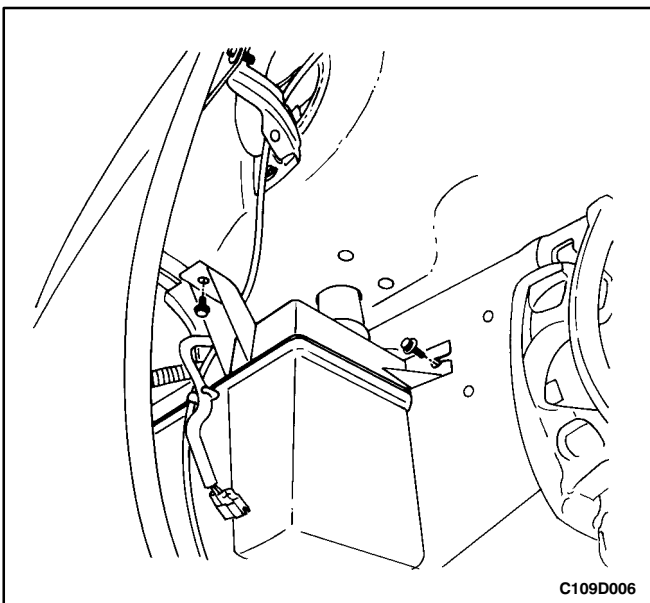

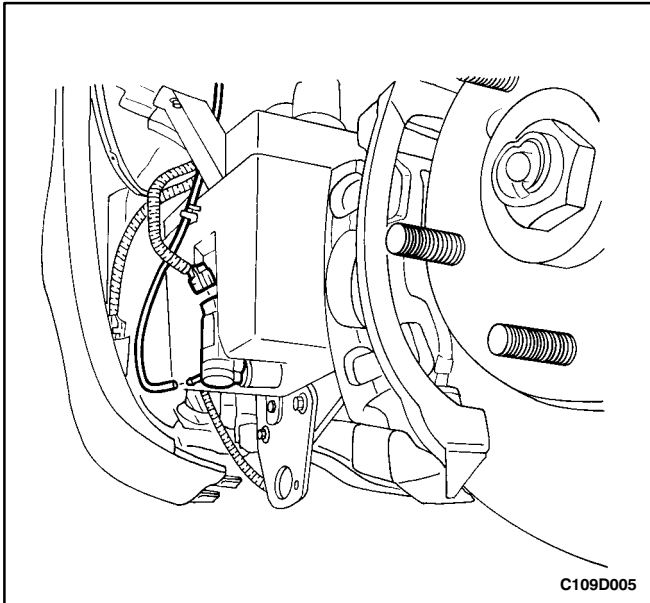

C109D005

2. Connect the reservoir pump electrical connector.
3. Connect the washer hose to the washer pump.
4. Install the front wheel well splash shield. Refer to *Section 9R, Body Front End*.
5. Install the front left wheel. Refer to *Section 2E, Tires and Wheels*.
6. Connect the negative battery cable.

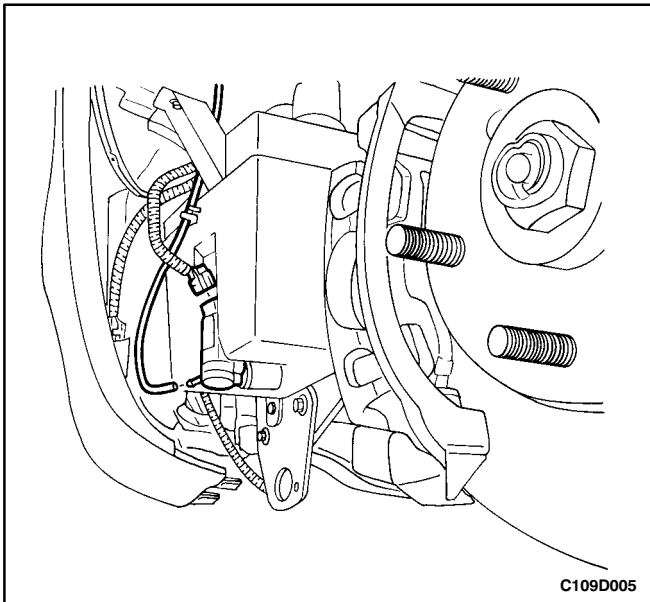

C109D005

## WINDSHIELD WASHER PUMP

### Removal Procedure

1. Disconnect the negative battery cable.
2. Remove the left front wheel. Refer to *Section 2E, Tires and Wheels*.
3. Remove the front wheel well splash shield. Refer to *Section 9R, Body Front End*.
4. Disconnect the electrical connector.
5. Disconnect the washer hose from the washer pump.
6. Remove the washer pump.

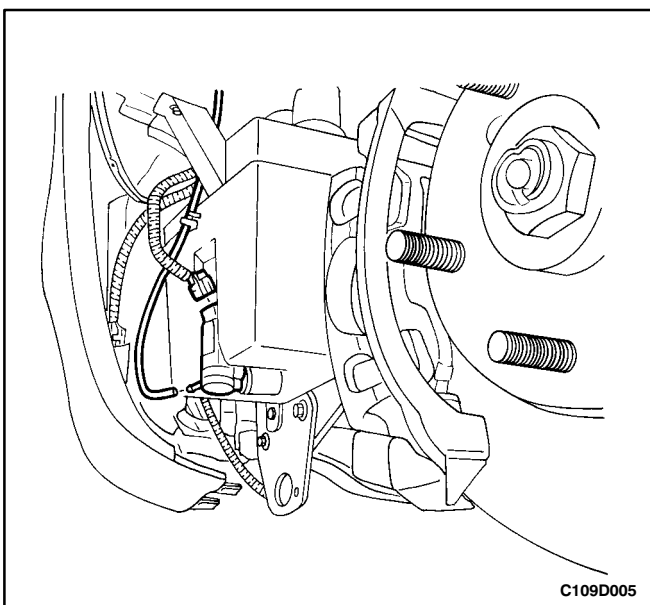

C109D005

### Installation Procedure

1. Install the washer pump.
2. Connect the washer hose to the washer pump.
3. Connect the electrical connector.
4. Install the front wheel well splash shield. Refer to *Section 9R, Body Front End*.
5. Install the left front wheel. Refer to *Section 2E, Tires and Wheels*.
6. Connect the negative battery cable.

## WINDSHIELD WASHER NOZZLES

### Removal Procedure

1. Open the hood.
2. Disconnect the washer hose from the nozzle.
3. Remove the nozzle from the hood.

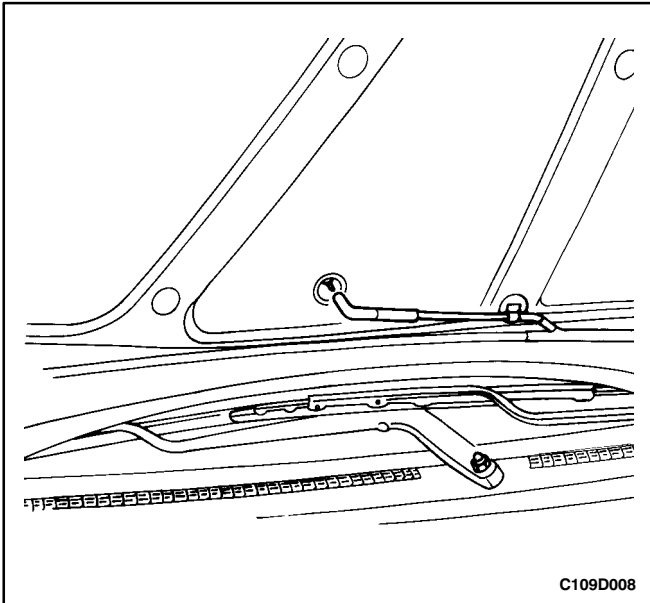

### Installation Procedure

1. Install the nozzle onto the hood.
2. Connect the washer hose to the nozzle.
3. Close the hood.

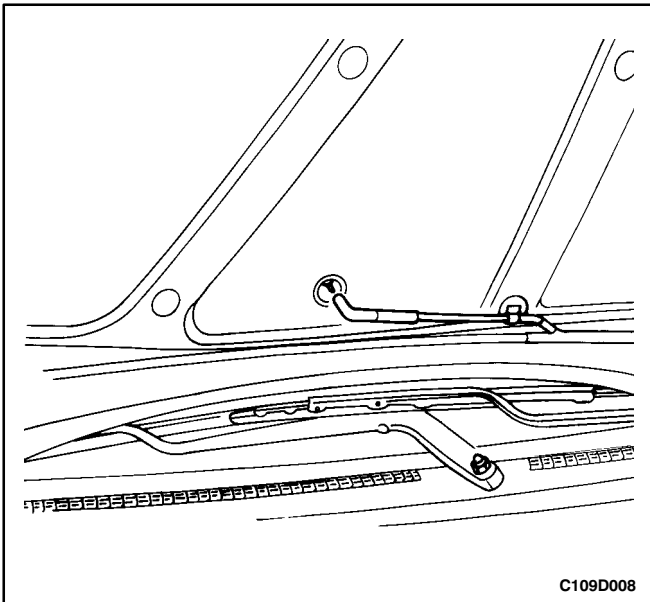

## WINDSHIELD WASHER HOSES

### Removal Procedure

1. Open the hood.
2. Disconnect the windshield washer hose from the washer nozzles on the hood.
3. Remove the front left wheel. Refer to *Section 2E, Tires and Wheels*.
4. Remove the front wheel well splash shield. Refer to *Section 9R, Body Front End*.
5. Disconnect the washer hose from the washer reservoir.
6. Remove the washer hose.

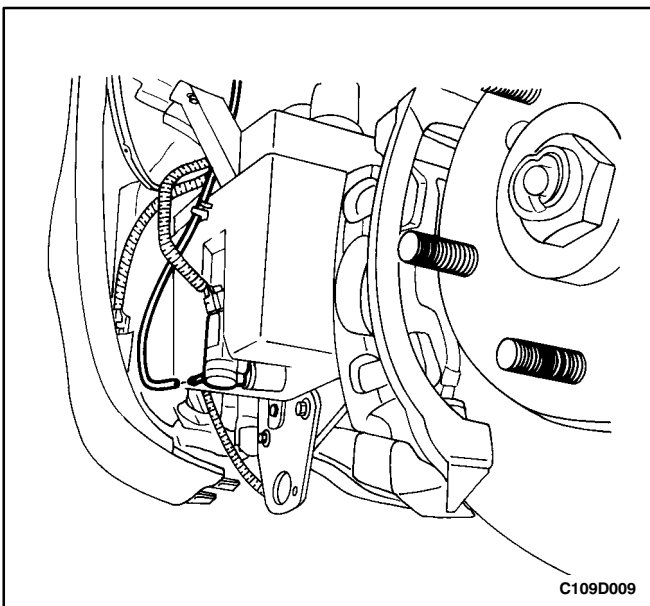

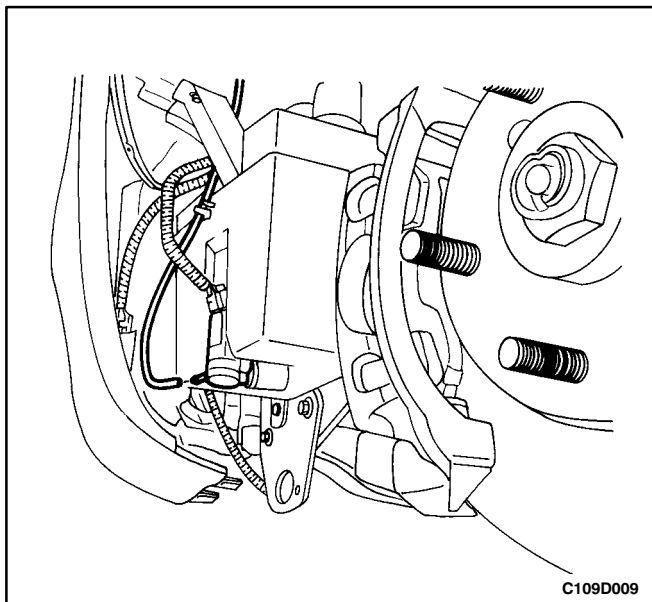

### Installation Procedure

1. Connect the washer hose to the washer pump.
2. Install the front wheel well splash shield. Refer to *Section 9R, Body Front End*.
3. Install the front left wheel. Refer to *Section 2E, Tires and Wheels*.
4. Connect the windshield washer hose to the washer nozzles on the hood.
5. Close the hood.

## **GENERAL DESCRIPTION AND SYSTEM OPERATION**

### **WINDSHIELD WIPER SYSTEM**

The windshield wiper system consists of a wiper motor, a linkage, a wiper arm and a blade, and a wiper/washer switch. The windshield wiper circuit incorporates a self-parking device which consists of a worm gear and a cam plate in order to keep the circuit engaged temporarily when the switch is turned off. The wiper system is driven by a permanent magnet-type motor. The windshield wiper motor is mounted on the dash panel and is directly connected to the windshield wiper linkage.

The windshield wiper motor has two speeds, LO and HI, and also has intermittent wiper capability. The wiper

switch is an integral part of the wiper/washer switch. Windshield wiper operation is actuated through the lever on the right side of the steering column.

### **WINDSHIELD WASHER SYSTEM**

The windshield washer system is equipped with a washer fluid reservoir, a washer fluid pump, hoses, nozzles, and a wiper/washer switch. The windshield washer reservoir is mounted behind the front left wheel well splash shield. Attached to the reservoir is a washer pump, which pumps fluid through the hoses to the two nozzles mounted on the hood. The washer switch is an integral part of the wiper/washer switch. Windshield washer operation is actuated through the lever on the right side of the steering column.